

Appareil simple cloison AG111 avec frein

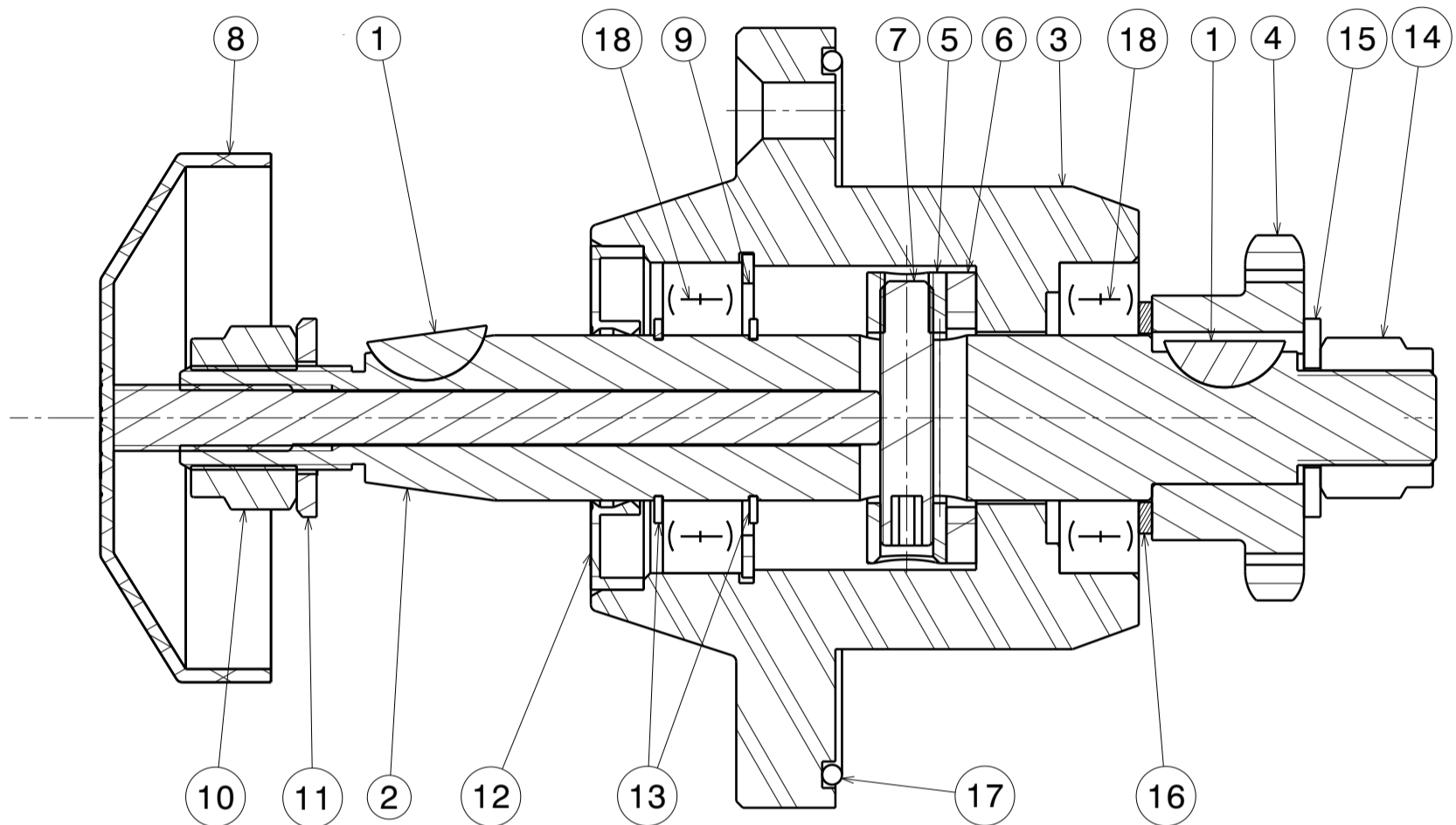

Number	Reference	Description	Désignation	Qty
1	106165	Half moon key	Clavette demi lune	2
2	116583	Shaft	Arbre	1
3	116588	Main body	Corps principal	1
4	106382	Sprocket pitch 15.875 - 10 teeth	Pignon pas 15.875 - 10 dents	1
	106303	Sprocket pitch 15.875 - 12 teeth	Pignon pas 15.875 - 12 dents	
	116481	Sprocket pitch 15.875 - 13 teeth	Pignon pas 15.875 - 13 dents	
	106381	Sprocket pitch 15.875 - 19 teeth	Pignon pas 15.875 - 19 dents	
5	116584	Braking disk	Disque presseur	1
6	115235	Braking washer	Rondelle frein	1
7	116543	Screw M8x40 DIN 913	Vis Hc M8x40 bout plat	1
8	116542	Brake thumb wheel	Molette de frein	1
9	116540	Internal circlip D47	Circlips intérieur D47	1
10	106168	Prevailing torque type hexagon nut with non metallic insert 5/8 UNF	Ecrou frein 5/8 UNF	1
11	94715	Washer M16	Rondelle M16	1
12	106169	Radial oil seal 25x52x8 type AD DIN 3760 profil A	Joint à lèvres 25x52x8	1
13	94478	External circlip D25	Circlips extérieur D25	2
14	106167	Prevailing torque type hexagon nut with non metallic insert 9/16 UNF	Ecrou frein 9/16 UNF	1
15	94714	Washer M14	Rondelle M14	1
16	116589 116590 116591	Nylon washer 25x35x2 (thickness adjusted for each system)	Rondelle nylon (épaisseur ajustée à chaque appareil)	1
17	106166	O-ring interior diameter 105x3	Joint torique 105x3	1
18	94498	Ball bearing 25 47 12 - 6005 2RS	Roulement étanche 25 47 12 type 6005 2RS	2